

# SCNR Government Degree College, Proddatur

## I Semester

### Course 2: ADVANCES IN MATHEMATICAL, PHYSICAL AND CHEMICAL SCIENCES

#### Syllabus:

#### **UNIT V: Advanced Applications of computer Science**

Number System-Binary, Octal, decimal, and Hexadecimal, Signals-Analog, Digital, Modem, Codec, Multiplexing, Transmission media, error detection and correction- Parity check and CRC, Networking devices-Repeater, hub, bridge, switch, router, gateway.

#### Number System:

Numeral system is the System of representing numbers.

#### **Types of Number Systems**

There are various types of number systems in mathematics. The four most common number system types are:

1. Decimal number system (Base- 10)
2. Binary number system (Base- 2)
3. Octal number system (Base-8)
4. Hexadecimal number system (Base- 16)

#### SIGNALS:

- A signal is an electrical representation of data. Signals can represent messages, images, sounds, measurements, and anything else defined as a set of values.
- Examples of signals include light, sound, temperature changes, and electrical voltage.
- Signals can be continuous or discrete

There are two primary types:

Analog SIGNALS and Digital SIGNALS

#### Analog Signals:

- Analog signal is a type of signal that represents continuous data using a continuous range of values.
- These signals are characterized by their amplitude, frequency and phase
- **Examples:** temperature, current, voltage, voice, pressure, speed, etc.
- The analog signals are used several applications like land line phones, thermometer, electric fan, Analog Watches, FM Radio etc.

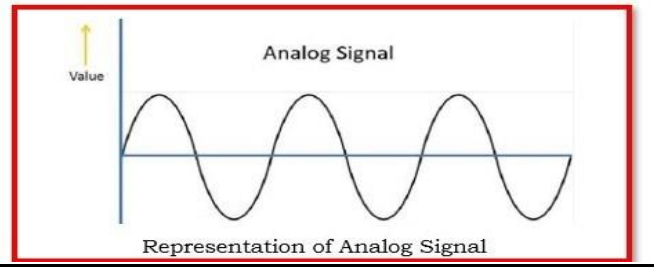

**Digital signal :**

- Digital signal is a type of signal that represents data as a sequence of discrete values, typically using binary numbers.
- The common example of digital signal is the data store in a computer memory.
- The digital signals are used in computers, digital watches, smartphones, Digital pen, Digital images & video signals, Digital Camera, etc.

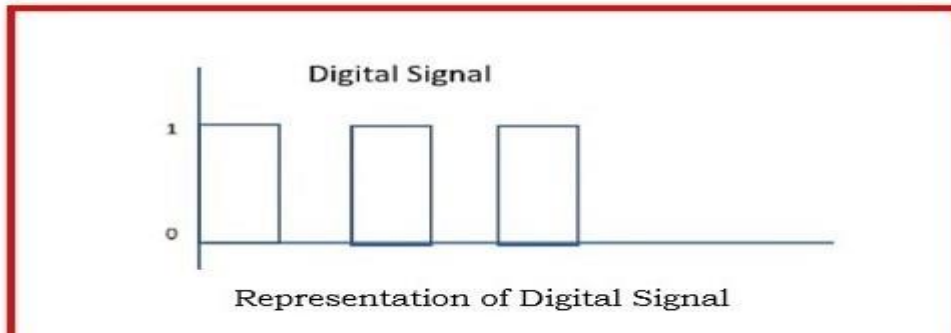

- Difference between Analog and Digital Signal

<ul style="list-style-type: none"> <li>• Analog Signals</li> </ul>	<ul style="list-style-type: none"> <li>• Digital Signals</li> </ul>
<ul style="list-style-type: none"> <li>• Continuous signals</li> </ul>	<ul style="list-style-type: none"> <li>• Discrete signals</li> </ul>
<ul style="list-style-type: none"> <li>• Represented by sine waves</li> </ul>	<ul style="list-style-type: none"> <li>• Represented by square waves</li> </ul>
<ul style="list-style-type: none"> <li>• Information is represented in Continuous range of values</li> </ul>	<ul style="list-style-type: none"> <li>• Discontinuous values</li> </ul>
<ul style="list-style-type: none"> <li>• Examples : temperature, current, voltage, voice, pressure, speed, etc.</li> </ul>	<ul style="list-style-type: none"> <li>• Examples: Data store in a computer memory.</li> </ul>
<ul style="list-style-type: none"> <li>• Applications: Land line phones, thermometer, electric fan, volume knob of a radio, etc.</li> </ul>	<ul style="list-style-type: none"> <li>• The digital signals are used in computers, keyboards, digital watches, smartphones, etc.</li> </ul>
<ul style="list-style-type: none"> <li>• More response to noise leads to reducing accuracy of signal.</li> </ul>	<ul style="list-style-type: none"> <li>• Digital signals are less affected due to noise when compared to analog signals.</li> </ul>
<ul style="list-style-type: none"> <li>• More power consumed by analog signal.</li> </ul>	<ul style="list-style-type: none"> <li>• Less power consumption.</li> </ul>



## Modem

- Modem stands for modulator/demodulator.
- A modulator converts the digital signals to analog signal. A demodulator converts the analog signals to digital signals.

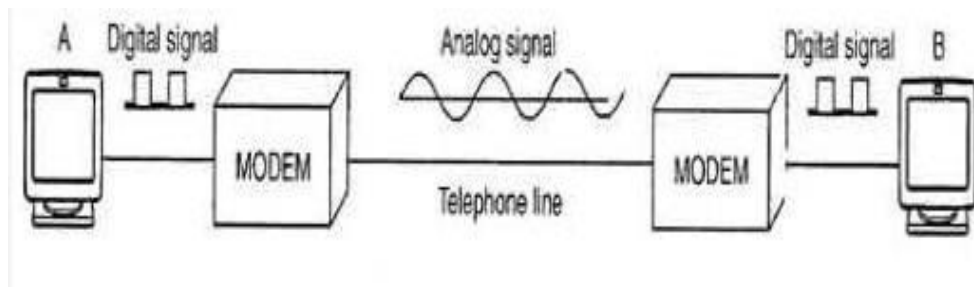

In Above diagram, the computer on the left sends a digital signal to the modulator portion of the modem; the data are sent as an analog signal on the telephone lines. The modem on the right receives the analog signal, demodulates it through its demodulator, and delivers data to the computer on the right. The communication can be bidirectional, which means the computer on the right can simultaneously send data to the computer on the left, using the same modulation/demodulation processes.

## codec

- codec (Compressor-DeCompressor or Coder-DECoder) is a software or hardware tool that:
- **Encodes (compresses)** data, such as audio or video files, to reduce their size and make them easier to transmit or store
- **Decodes (decompresses)** the compressed data back into its original form, allowing it to be played back or edited.
- Codecs are used in audio, video, image, streaming of audio and video content and play back media files on device.

### **Examples of Codec:**

- audio files (e.g., MP3, AAC)
- video files (e.g., H.264, MPEG-4)
- image files (e.g., JPEG, PNG)
- Stream audio and video content online (e.g., YouTube, Netflix)
- Play back media files on devices (e.g., Windows Media Player, VLC)

They are following types of compressors

**Lossless:** compress data without losing quality (e.g., FLAC, PNG)

**Lossy:** compress data by discarding some of the data (e.g., MP3)

## Multiplex

- Multiplexing is the sharing of a medium or bandwidth.
- It is the process in which multiple signals coming from multiple sources are combined and transmitted over a single communication/ physical line.



**Types of Multiplex:**

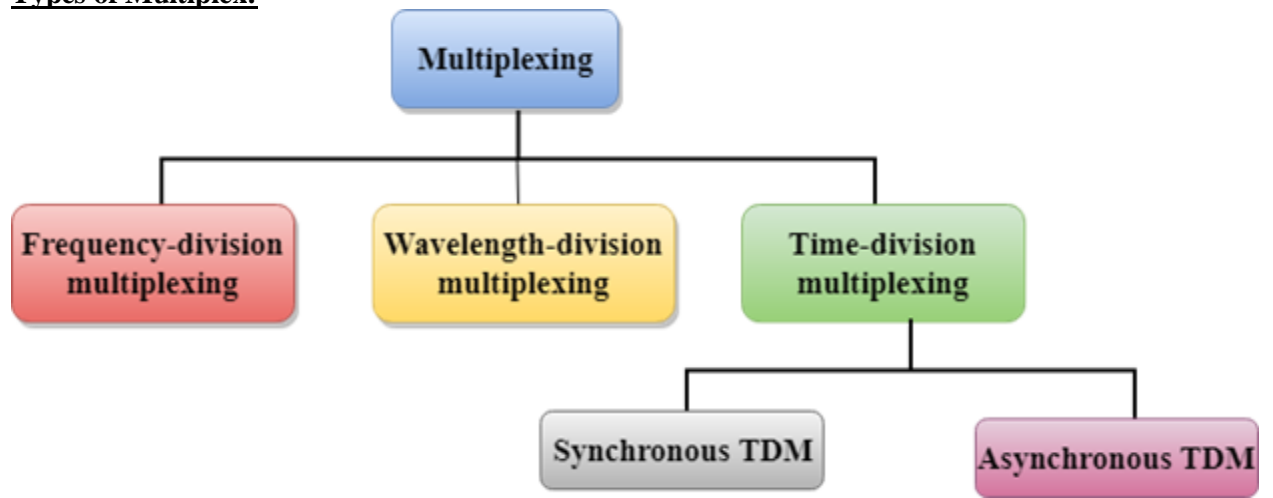

**Frequency-division Multiplexing (FDM):**

- It is an analog technique.
- **Frequency Division Multiplexing** is a technique in which the available bandwidth of a single transmission medium is subdivided into several channels.

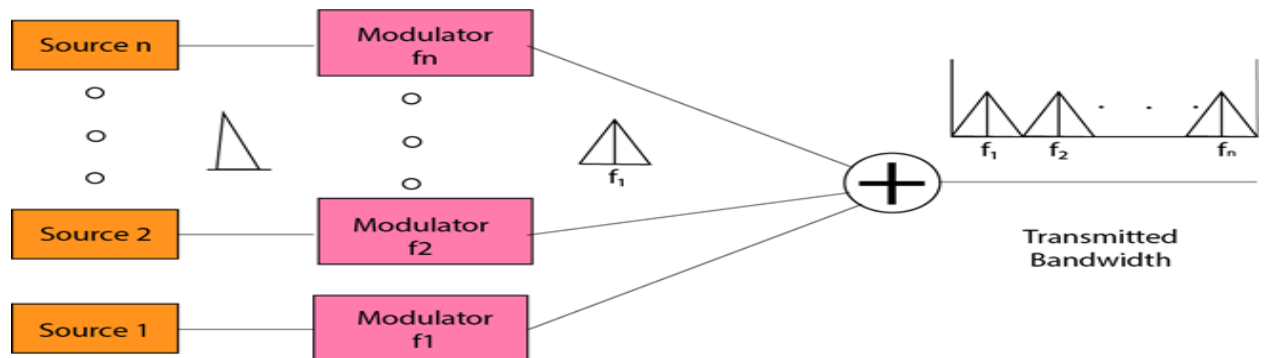

**Advantages Of FDM:**

- FDM is used for analog signals.
- FDM process is very simple and easy modulation.
- A Large number of signals can be sent through an FDM simultaneously.
- It does not require any synchronization between sender and receiver.

**Disadvantages Of FDM:**

- FDM technique is used only when low-speed channels are required.
- It suffers the problem of crosstalk.
- A Large number of modulators are required.
- It requires a high bandwidth channel.

**Applications Of FDM:**

FDM is commonly used in TV networks.  
It is used in Radio networks.

### Wavelength Division Multiplexing (WDM):

- Wavelength Division Multiplexing is same as FDM except
- that the optical signals are transmitted through the fibre optic cable.
- It is used to utilize the high data rate capability of fibre optic cable.
- It is an analog multiplexing technique.
- Optical signals from different source are combined to form a wider band of light with the help of multiplexer.
- At the receiving end, demultiplexer separates the signals to transmit them to their respective destinations.
- Multiplexing and Demultiplexing can be achieved by using a prism.

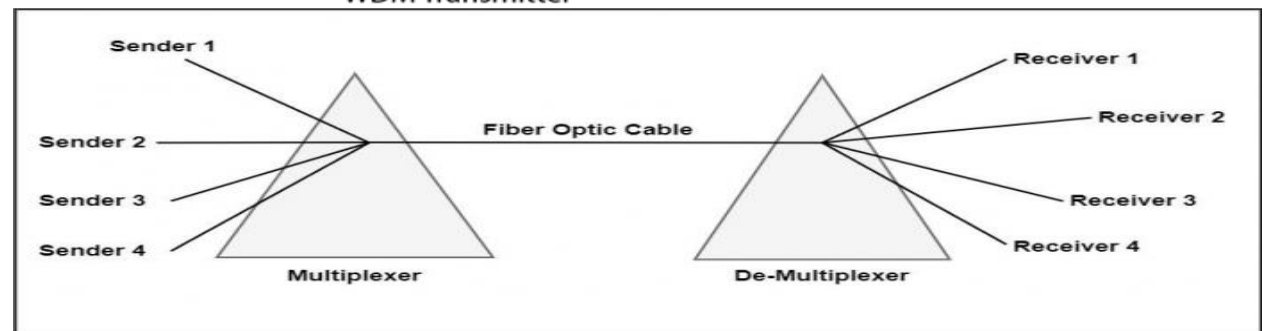
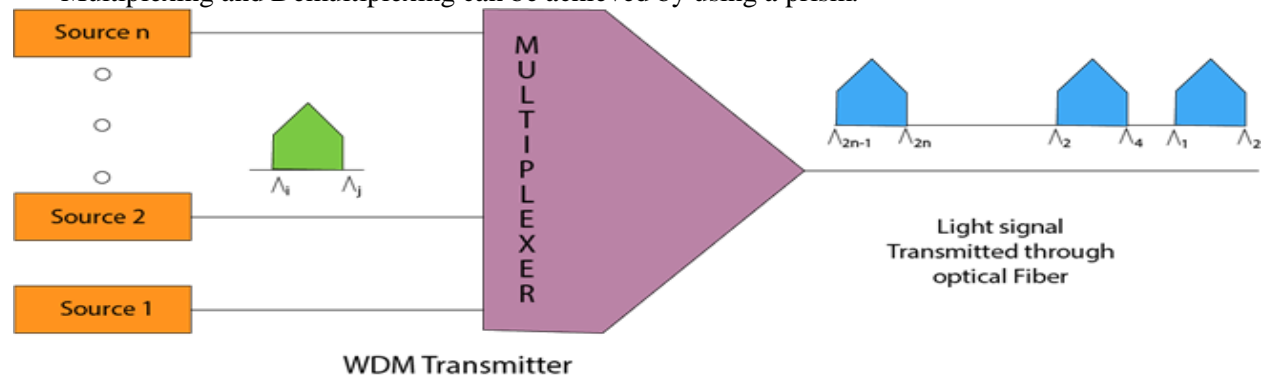

### **Advantages-**

- Extreme security
- It offers more bandwidth.
- There is possibility of transmission in full duplex mode.
- This strategy might work best because it is straightforward to implement.

### **Disadvantages-**

- Tuning of wavelengths is difficult
- Bandwidth is not efficiently utilized.
- The system becomes more expensive as optical components are added.

### **Applications:**

The application of WDM is the Synchronous Optical Network (SONET)

### Time Division Multiplexing:

- It is a digital technique.
- In Frequency Division Multiplexing Technique, all signals operate at the same time with different frequency, but in case of Time Division Multiplexing technique, all signals operate at the same frequency with different time.
- In **Time Division Multiplexing technique**, the total time available in the channel is distributed among different users. Therefore, each user is allocated with different time interval known as a Time slot at which data is to be transmitted by the sender.

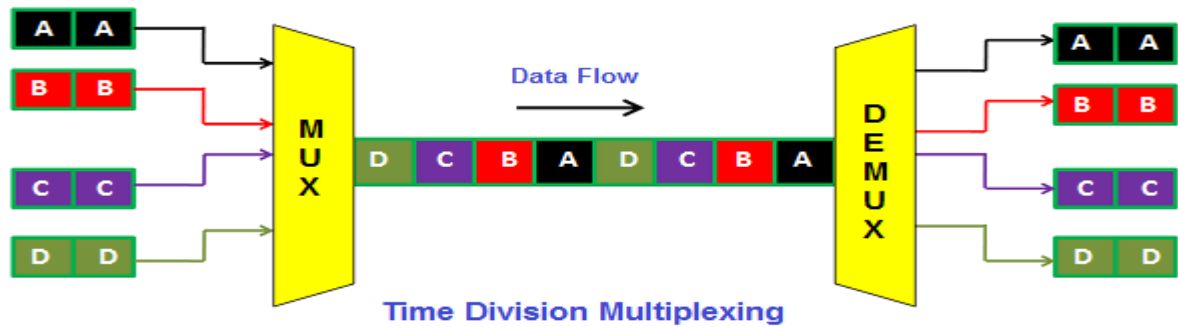

• There are two types of TDM:

1. Synchronous TDM
2. Asynchronous TDM

**synchronous TDM:**

- Each device is allocated with some time slot. The time slots are transmitted irrespective of whether the sender has data to send or not.

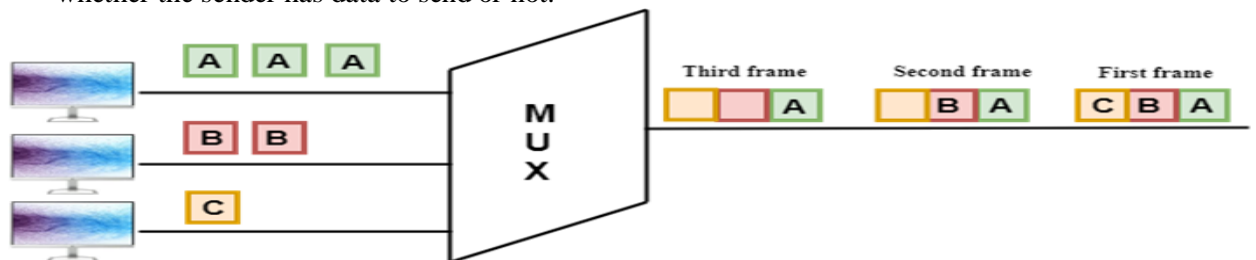

**Asynchronous TDM:**

- An asynchronous TDM is also known as Statistical TDM.
- An asynchronous TDM technique dynamically allocates the time slots to the devices.
- In Asynchronous TDM, total speed of the input lines can be greater than the capacity of the channel.

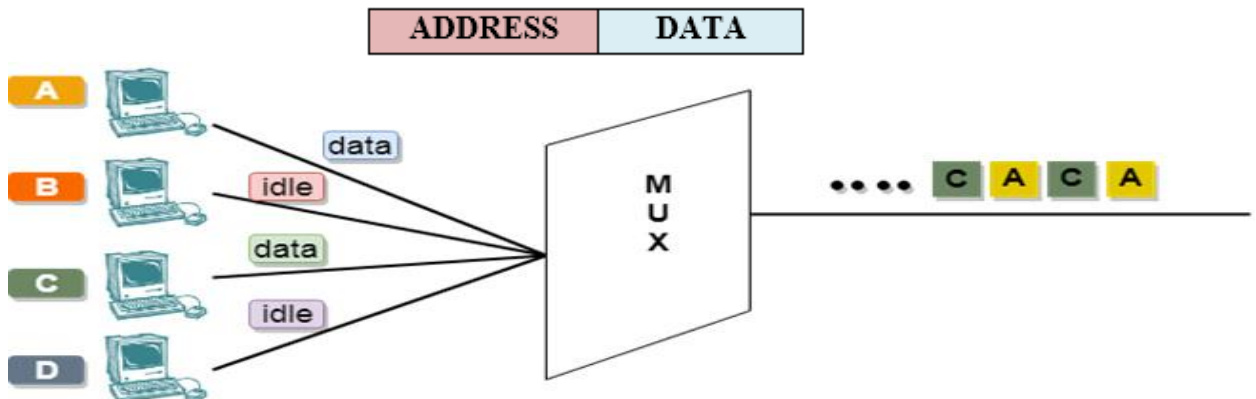

**Advantages:**

- [Time division multiplexing](#) systems are more flexible than frequency division multiplexing.
- Time division multiplexing circuitry.
- Problem of cross talk is not severe.
- Full available channel bandwidth can be utilized for each channel.

**Disadvantage:**

- Synchronization is required in time division multiplexing.
- Complex to implement.

**Applications of TDM:**

- Multiple users sharing a printer
- Intersection traffic lights:
- Telecommunications, Broadcast and multimedia, Digital signal processing, Networking, Video surveillance

## Transmission Media

- Transmission media is a communication channel that carries the information from the sender to the receiver. Data is transmitted through the electromagnetic signals.
- The electromagnetic signals can be sent through the copper wire, fibre optics, atmosphere, water, and vacuum.
- The characteristics and quality of data transmission are determined by the characteristics of medium and signal.
- In wired media, medium characteristics are more important whereas, in wireless media, signal characteristics are more important.
- The transmission media is available in the lowest layer of the OSI(Open System Interconnection) reference model, i.e., **Physical layer**.

## Classification Of Transmission Media:

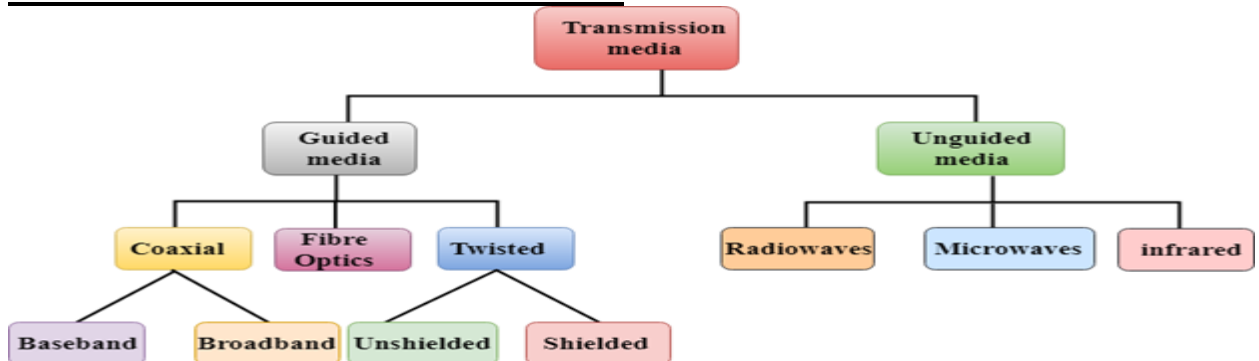

### Guided Media:

- It is defined as the physical medium through which the signals are transmitted. It is also known as Bounded media.

### Twisted pair:

- Twisted pair is a physical media made up of a pair of cables twisted with each other.
- the frequency range for twisted pair cable is from 0 to 3.5KHz.

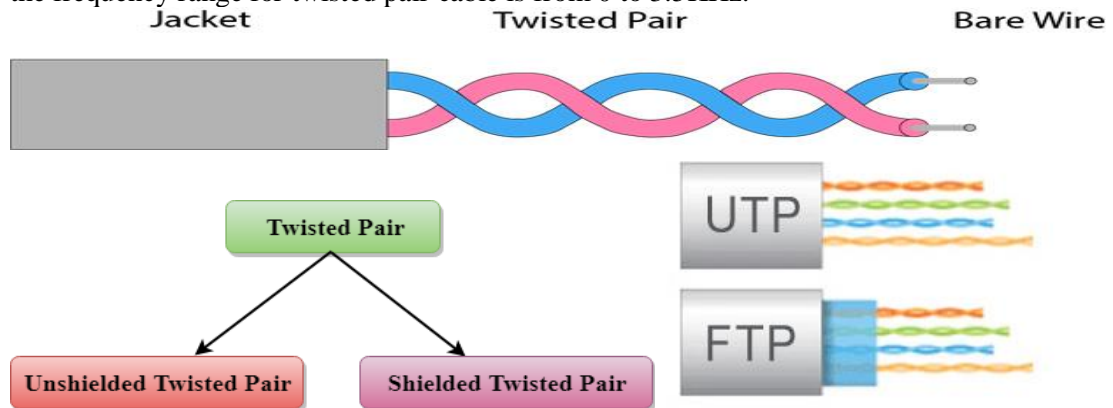

### unshielded twisted pair:

An unshielded twisted pair is widely used in telecommunication.

Following are the categories of the unshielded twisted pair cable:

- Category 1: Category 1 is used for telephone lines that have low-speed data.
- Category 2: It can support upto 4Mbps.
- Category 3: It can support upto 16Mbps.
- Category 4: It can support upto 20Mbps.
- Category 5: It can support upto 200Mbps.

### Advantages:

- Least expensive
- Easy to install
- High-speed capacity

**Disadvantages:**

→→→ Lower capacity and performance in comparison to STP

**Shielded Twisted Pair:**

A shielded twisted pair is a cable that contains the mesh surrounding the wire that allows the higher transmission rate.

- It has a higher attenuation rate.

**Advantages:**

→→ Better performance at a higher data rate in comparison to UTP

→→ Eliminates crosstalk

→→ Comparatively faster

**Disadvantages:**

→→ Comparatively difficult to install and manufacture

→→ More expensive

→→ Bulky

**Coaxial Cable:**

- It has an outer plastic covering containing an insulation layer made of PVC or Teflon and 2 parallel conductors each having a separate insulated protection cover.

- It has a higher frequency as compared to Twisted pair cable.

**Coaxial cable is of two types:**

- **Baseband transmission:** It is defined as the process of transmitting a single signal at high speed.

- **Broadband transmission:** It is defined as the process of transmitting multiple signals simultaneously.

**Examples:**

TV wire is usually a coaxial cable., digital audio (S/PDIF)

, computer network connections (like Ethernet)

**Advantages:**

- High Bandwidth
- Better noise Immunity
- Easy to install and expand
- Inexpensive

**Disadvantages:**

- Single cable failure can disrupt the entire network



Figure of Coaxial Cable

**Optical Fibre Cable:**

- The core is surrounded by a less dense glass or plastic covering called the cladding. It is used for the transmission of large volumes of data.

- The cable can be unidirectional or bidirectional.

**Advantages:**

- Increased capacity and bandwidth
- Lightweight
- Less signal attenuation
- Immunity to electromagnetic interference

**Disadvantages:**

- Difficult to install and maintain
- High cost
- Fragile

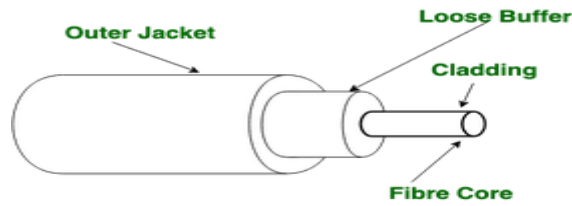

Figure of Optical Fibre Cable

### Unguided Transmission Media:

- An unguided transmission transmits the electromagnetic waves without using any physical medium. Therefore it is also known as wireless transmission.
- In unguided media, air is the media through which the electromagnetic energy can flow easily.

### Radio waves:

- Radio waves are the electromagnetic waves that are transmitted in all the directions of free space.
- Radio waves are **omnidirectional**, i.e., the signals are propagated in all the directions.
- The range in frequencies of radio waves is from 3Khz to 1 Ghz.
- In the case of radio waves, the sending and receiving antenna are not aligned, i.e., the wave sent by the sending antenna can be received by any receiving antenna.
- An example of the radio wave is **FM radio**, cordless phones .

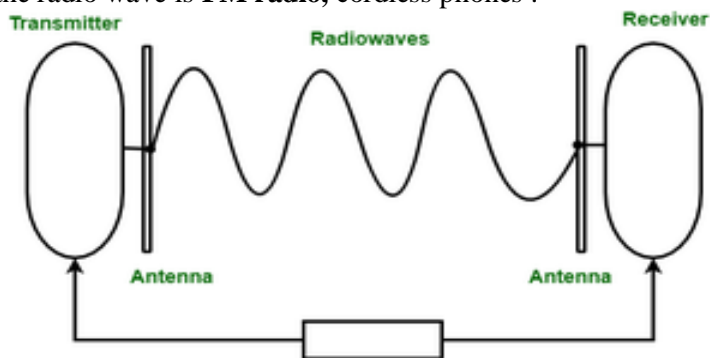

### Microwaves:

- It is a line of sight transmission i.e. the sending and receiving antennas need to be properly aligned with each other.
- The distance covered by the signal is directly proportional to the height of the antenna.
- Frequency Range:1GHz – 300GHz.
- These are majorly used for mobile phone communication and television distribution.



Fig: Microwave Transmission

### Infrared:

- Infrared waves are used for very short distance communication. They cannot penetrate through obstacles.
- This prevents interference between systems.
- Frequency Range:300GHz – 400THz.
  - It is used in TV remotes, wireless mouse, keyboard, printer, etc.



### Error Detection & Correction

- There are many reasons such as noise, cross-talk etc., which may help data to get corrupted during transmission.

There may be three types of errors:

- **Single bit error:**

In a frame, there is only one bit, anywhere though, which is corrupt.



- **Multiple bits error:**

Frame is received with more than one bits in corrupted state.



- **Burst error:**

Frame contains more than 1 consecutive bits corrupted.

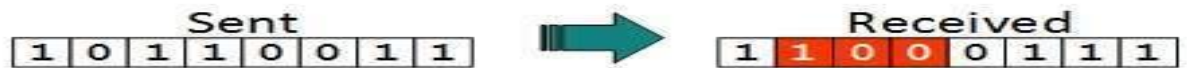

Error control mechanism may involve two possible ways:

- **Error detection:** Parity check, Checksum, CRC.
- **Error correction**

### Error Detection Methods:

#### **Simple Parity Check**

- Simple-bit parity is a simple error detection method that involves adding an extra bit to a data transmission.

**It works as:**

- 1 is added to the block if it contains an odd number of 1's, and
- 0 is added if it contains an even number of 1's
- This scheme makes the total number of 1's even, that is why it is called even parity checking.

**Dis advantage:**

- If a single bit flips in transit, the receiver can detect it by counting the number of 1s. But when more than one bits are erroneous, then it is very hard for the receiver to detect the error.

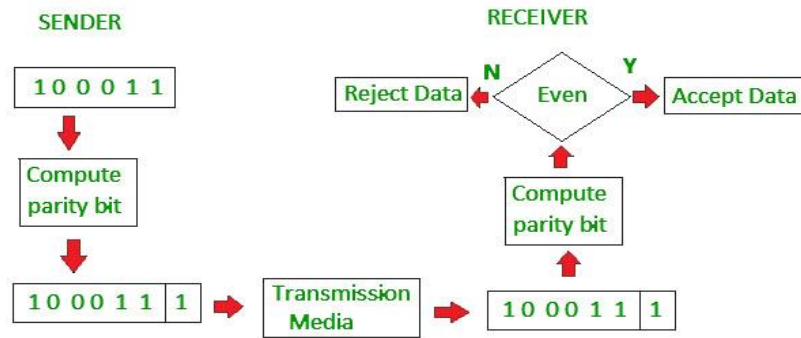

**Two-dimensional Parity Check:**

- Two-dimensional Parity check bits are calculated for each row, which is equivalent to a simple parity check bit. Parity check bits are also calculated for all columns, then both are sent along with the data. At the receiving end, these are compared with the parity bits calculated on the received data.

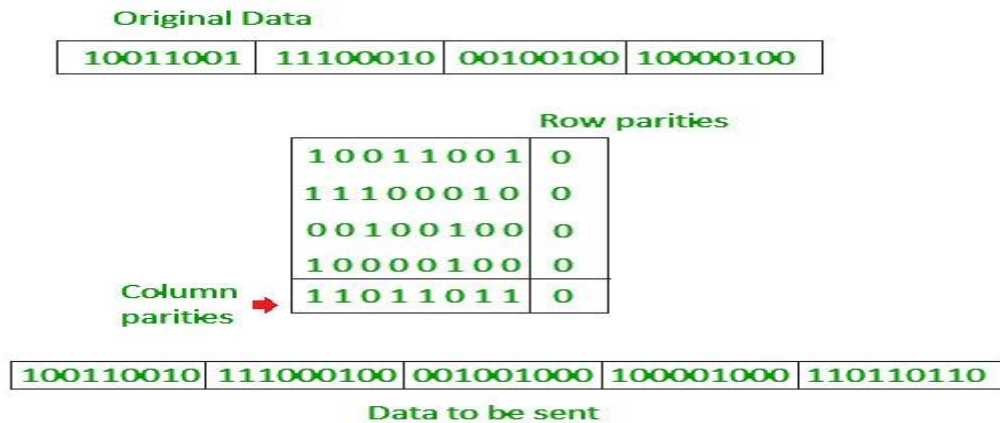

**Cyclic Redundancy Check (CRC):**

- CRC is based on binary division.
- In CRC, a sequence of redundant bits, called cyclic redundancy check bits, are appended to the end of the data unit so that the resulting data unit becomes exactly divisible by a second, predetermined binary number.
- At the destination, the incoming data unit is divided by the same number. If at this step there is no remainder, the data unit is assumed to be correct and is therefore accepted otherwise data unit has been damaged in transit and therefore must be rejected.

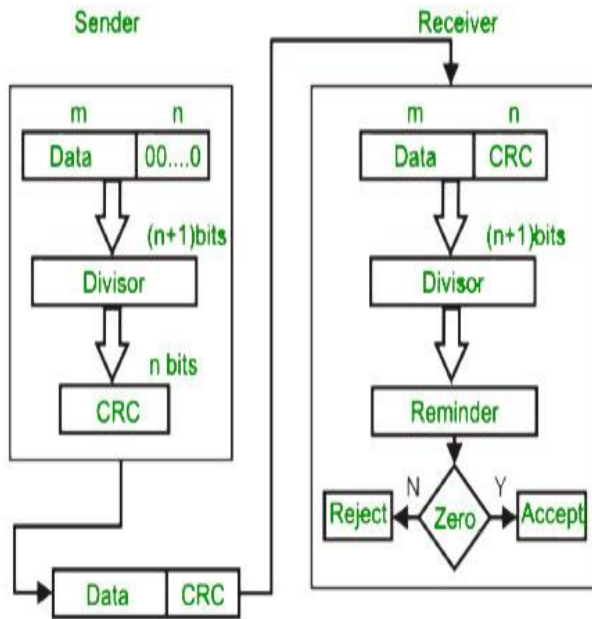

**original message**  
1 0 1 0 0 0 0

@ means X-OR

**Generator polynomial**  
 $x^3+1$   
 $1 \cdot x^3 + 0 \cdot x^2 + 0 \cdot x^1 + 1 \cdot x^0$   
**CRC generator**  
1 0 0 1 4-bit

If CRC generator is of n bit then append (n-1) zeros in the end of original message

**Sender**

```

1 0 0 1 | 1 0 1 0 0 0 0 0 0 0
@ 1 0 0 1
0 0 1 1 0 0 0 0 0 0
@ 1 0 0 1
0 1 0 1 0 0 0 0
@ 1 0 0 1
0 0 1 1 0 0 0
@ 1 0 0 1
0 1 0 1 0
@ 1 0 0 1
0 0 1 1

```

**Message to be transmitted**  
1 0 1 0 0 0 0 0 0 0  
+ 0 1 1  
1 0 1 0 0 0 0 1 1

**Receiver**

```

1 0 0 1 | 1 0 1 0 0 0 0 0 1 1
@ 1 0 0 1
0 0 1 1 0 0 0 0 1 1
@ 1 0 0 1
0 1 0 1 0 0 1 1
@ 1 0 0 1
0 0 1 1 0 1 1
@ 1 0 0 1
0 1 0 0 1
@ 1 0 0 1
0 0 0 0

```

Zero means data is accepted

### **Error correction:**

In the digital world, error correction can be done in two ways:

#### **Backward Error Correction:**

When the receiver detects an error in the data received, it requests back the sender to retransmit the data unit.

#### **Forward Error Correction:**

When the receiver detects some error in the data received, it executes error correcting code, which helps it to auto recover and to correct some kinds of errors.

Hamming Code:

r is the number of redundant bits and d is the total number of the data bits. The number of redundant bits r can be calculated by using the formula:

$$2^r \geq d + r + 1$$

### **Network Devices**

- Network devices, also known as networking hardware, are physical devices that allow hardware on a computer network to communicate and interact with one another.
- For example : Repeater, Hub, Bridge, Switch, Routers, Gateway etc.,

#### **Repeater:**

- Repeaters are a networking device that is used to amplify and regenerate the incoming signal.
- Repeaters work at the physical layer of the OSI model.
- The main aim of using a repeater is to increase the networking distance by increasing the strength and quality of signals.
- The performance of Local Area Networks (LANs) and Wide Area Networks (WANs) repeaters are used.
- Using repeaters helps to reduce error, and loss of data and provides with delivery of data at specified locations only.
- The major advantage of using a repeater is that it provides with transfer of data with more security and over a long distance.

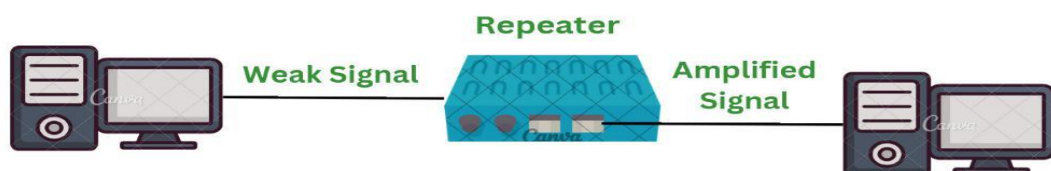

### HUB:

- A hub is a physical layer networking device which is used to connect multiple devices in a network.
- They are generally used to connect computers in a LAN.
- A hub has many ports in it. A computer which intends to be connected to the network is plugged in to one of these ports. When a data frame arrives at a port, it is broadcast to every other port, without considering whether it is destined for a particular destination or not.

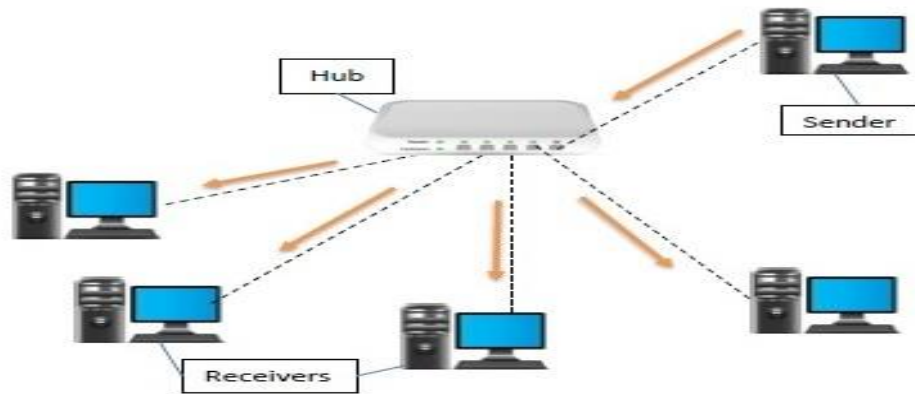

### Switches:

- A switch is a networking device which connects devices in a network and uses to send and receive data over the network.
- They operate in the data link layer of the OSI model.
- They are active devices, equipped with network software.
- The number of ports is higher – 24/48.
- Like a hub, a switch also has many ports, to which computers are plugged in. However, when a data frame arrives at any port of a network switch, it examines the destination address and sends the frame to the corresponding device(s). Thus, it supports both unicast and multicast communications.

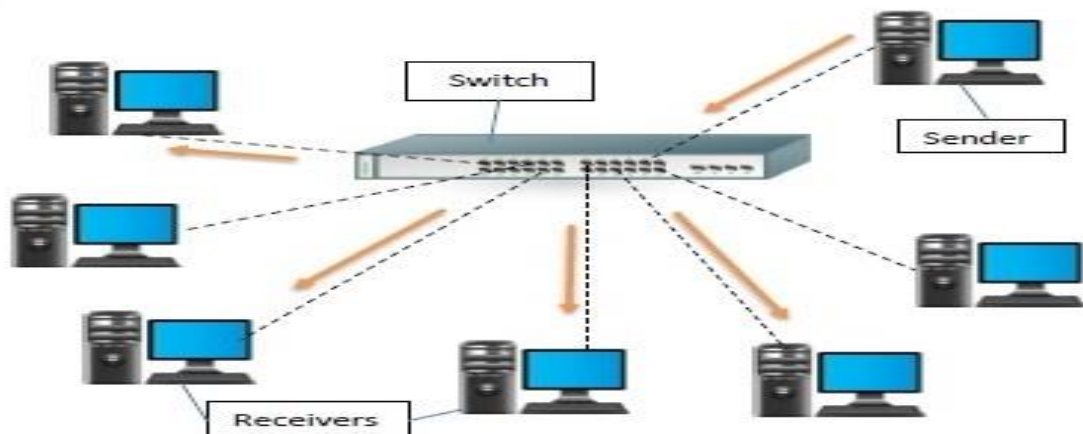

### Bridges:

A bridge is a device that connects multiple LAN (Local Area Network) segments and acts as an intermediary between them.

- Bridges operate at the data link layer of the OSI model and use MAC addresses to forward data packets between networks.
- There are several types of bridges, including wired, wireless, and layer 2 switching bridges.
- Bridges can improve network performance and efficiency by reducing broadcast traffic and providing a more efficient path for data transmission.

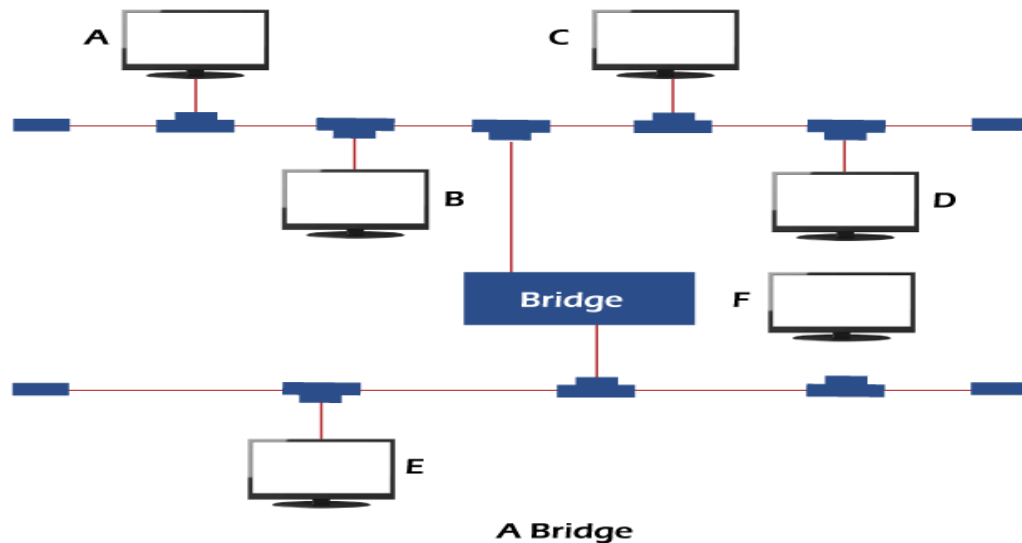

### Routers:

- In computer networks, a router is a device that routes data packets between different networks.
- It uses routing tables and protocols to determine the best path for data to travel, based on factors such as network congestion and cost.
- It shares information with other routers in networking.
- It uses the routing protocol to transfer the data across a network.
- Furthermore, it is more expensive than other networking devices like switches and hubs.
- There are some popular companies that develop routers such as **Cisco, 3Com, HP, Juniper, D-Link, Nortel**, etc.
- Routers can be used to connect local area networks (LANs), wide area networks (WANs), and the internet, and can perform functions such as firewall protection, network address translation (NAT), and virtual private network (VPN) termination.

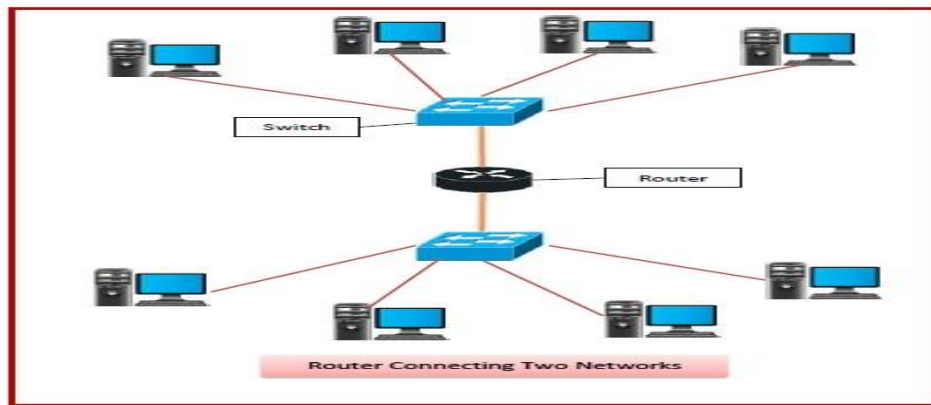

**Gateway:**

- In computer networks, a gateway is a device or software component that connects and facilitates communication between different networks with distinct architectures, protocols, or communication standards.
- Gateways operate at the network layer (Layer 3) of the OSI model .
- A gateway in a network converts information from one protocol to another and then transfers it over the web.
- It performs functions such as protocol translation, address translation, and data format conversion.
- For example, if a computer on the Internet sends an email to another, the gateway converts the message from one protocol to another and sends it back.
- Gateway is located at the boundary of a network and manages all data that inflows or outflows from that network.

For example, an Internet Gateway connects a local network to the internet, allowing devices within the network to access online resources.

